

LEGEND[®]

640 Loader Series

For 55-100 HP JD Tractors



200 N. Cleveland • Lennox, SD 57039

Toll Free: (855) 534-3784

Fax: (605) 647-1050

www.legendequip.com

08/08/2014

CONTENTS

CONTENTS	PAGE
Introduction	1
SAFETY INFORMATION	
Safety Alert Symbol	2
Safety Information.....	3-5
Safety Decals	6
Tractor & Safety Pointers	7
ASSEMBLY INSTRUCTIONS	
Attaching Loader	8-9
Attaching JD 600 - 700 Series Bucket	10
Attaching Global Bucket.....	11
Detaching Loader	12-13
Detaching JD 600 - 700 Series Bucket.....	14
Detaching Global Bucket.....	15
OPERATING INSTRUCTIONS	
Operation	16
SERVICE AND MAINTENANCE	
Specifications	17-18
Loader Inspection, Service and Maintenance.....	19
640 SL Loader Parts Diagram	20-21
640 SL Parts Identification Schedule	22-23
640 SL Global Loader Parts Diagram.....	24-25
640 SL Global Parts Identification Schedule.....	26-27
640 SL Loader Hydraulic Parts Diagram	28
640 SL Hydraulic Parts Identification Schedule	29
640 NSL Loader Parts Diagram	30-31
640 NSL Parts Identification Schedule	32-33
640 NSL Global Loader Parts Diagram.....	34-35
640 NSL Global Parts Identification Schedule.....	36-37
640 NSL Loader Hydraulic Parts Diagram	38
640 NSL Hydraulic Parts Identification Schedule	39
JD 600 - 700 Series Bucket Diagram	40
Bucket Parts Schedule	41
Hydraulic System Information	42
Hydraulic Cylinders Information	43
Hydraulic System Parts Diagram	44
Hydraulic System Parts List	45
3 1/4" Cylinder Service Kit	46
2 1/2" Cylinder Service Kit	47
Cylinder Gland & Piston Diagram	48
LIMITED WARRANTY INFORMATION	
Limited Warranty	49
TORQUE SPECIFICATIONS	
Torque Specifications	50

INTRODUCTION

TO THE PURCHASER

You have purchased an excellent product. With proper care and use, it will give you years of good safe service. Use only **LEGEND EQUIPMENT** approved parts in the general maintenance and repair of your equipment. **Please fill out ownership registration card as soon as possible.**

Should you have any questions regarding operation of your new LEGEND loader please contact a LEGEND EQUIPMENT company sales representative at 1-855-534-3784 or refer to our company website www.legendequip.com.

We care about your safety!

Remember ALL safety decals are no charge from the factory. Please replace all safety decals if missing or damaged. Your safety is important to us.

SAFETY ALERT SYMBOL

The symbol shown below is used to call your attention to instructions concerning your personal safety. Watch for this symbol it points out important safety precautions. It means **ATTENTION! Become Alert! Your Personal Safety Is Involved!**

Read the message that follows and be alert to the possibility of personal injury or death.

DANGER: Indicates an imminently hazardous situation that, if not avoided, will result in death or serious injury.

WARNING: Indicates a potentially hazardous situation that, if not avoided, could result in death or serious injury.

CAUTION: Indicates a potentially hazardous situation that, if not avoided may result in minor or moderate injury.



WARNING!

Anyone who will operate or work around a front-end loader should first read this manual.

SAFETY INFORMATION - (continued)

Improper use of a loader can cause serious injury or death. The following safety precautions, and those given on the tractor mount installation instructions should be thoroughly understood before attempting to operate this machine.

BEFORE OPERATING:

Carefully study and understand this manual, the specific tractor mount instructions, and the attachment(s) manual(s).

Prior to operation, inspect the loader for system leaks and damaged, missing, or malfunctioning components in an effort to avoid the possibility of a dangerous failure involving structural members or hydraulic system components.

Be certain any repairs necessary are completed prior to loader operation.

Follow recommended loader inspection, service and maintenance on Page 17.

Completely familiarize yourself and others involved with the operation of the hydraulic control valve before operating the loader.

Be certain all bystanders are clear of the machine and operation area prior to operation.

It may be necessary to add wheel ballast or rear weights as recommended by the tractor manufacturer to maintain stability of the machine to prevent tipping or upset which could result in serious injury or death. See mounting instructions for specific information.

It is recommended that both front and rear wheel treads be set to the widest recommended width to prevent tipping or upset which could result in serious injury or death.

This loader is designed for farm type operations such as snow removal, barn and feedlot cleaning, light commercial or light grading and digging. It's design is **NOT** intended for industrial use.

DURING OPERATION:

Never operate the machine other than from the tractor operator's seat.

Be sure operating area is clear of others during machine operations.

Never lift, hoist, or carry humans in the bucket or on any portion of the loader or loader attachments. Failure to heed, may result in serious injury or death.

SAFETY INFORMATION – (continued)

Transport the machine load at the slowest speed possible and with the loader boom at the lowest transport position to avoid tipping or upsetting, which may result in serious injury or death.

Be extremely careful when working on inclines or near loose fill, rocks, and holes as they can cause tipping or upsetting which may result in serious injury or death.

Be certain to avoid overhead electrical wires when operating loader. Contact with power lines may cause serious injury or death.

Avoid sudden stops when lowering or lifting the loader boom to prevent loss of control over the machine and/or load, which may result in serious injury or death.

Use maximum ballast and the widest recommended wheel setting on your tractor when handling large shiftable loads.

Never attempt to ram with the bucket at high speed or full tractor power. Sudden impact may result in structural failure and possible serious injury or death.

Never adjust or perform maintenance on the loader or tractor with the unit in motion, or without power source locked out.

Never get under bucket or lift arms or reach through the lift arms or bucket linkage when the loader is in operation. Inadvertent movement may cause serious injury or death.

FOLLOWING OPERATION:

Whenever the machine is not in operation, lower the loader boom and set the tractor brakes, disengage drive, shut the engine off, and remove the ignition key before dismounting the tractor.

If loader is to be disengaged from tractor, be sure the loader is securely supported on a hard, level surface and the stand is securely engaged. Be certain all connections between tractor and loader are free before disengaging.

TRANSPORTING:

Use safety lights and SMV emblem in addition to whatever local codes require when equipment is being transported on the road or highway. Check with proper authorities for legal limitations.

Transport all loads at a slow and safe speed.

Carry the load as low as possible and maintain adequate visibility and good round clearance at all times.

SAFETY INFORMATION - (continued)

PERFORMING MAINTENANCE:

Carefully review, understand, and follow the “maintenance” section in this owners manual before attempting to service loader.

Lower the bucket or attachment to the ground, shut off tractor engine, and relieve pressure in the hydraulic system before adjusting, lubricating, or servicing the loader.

Escaping hydraulic oil under pressure can penetrate the skin. Never use any part of your body to check for hydraulic leaks. Use cardboard when checking for leaks. See Fig. 5-1. Relieve hydraulic pressure before disconnecting any hydraulic line. Failure to heed may result in serious injury or death.

Before disconnecting hydraulic lines, lower the loader and attachments. Lock out the hydraulic supply and relieve all hydraulic pressure.

Replace any damaged or painted-over decals. See Page 6 for replacement decals.

REMEMBER:

1. Move Slowly!
2. Always use care and common sense!
3. Be careful for your own sake and for that of others!
4. Legend loaders include all reasonable means for accident prevention except a safe and careful operator.

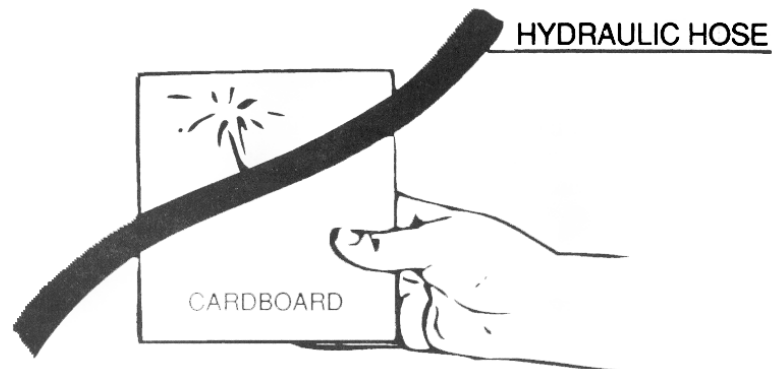



FIG. 5-1

SAFETY DECALS

	<h2 style="margin: 0;">⚠ WARNING</h2>
	<p style="text-align: center;">HIGH-PRESSURE FLUID HAZARD</p> <p>To prevent serious injury or death:</p> <ul style="list-style-type: none"> Relieve pressure on hydraulic system before servicing or disconnecting hoses. Wear proper hand and eye protection when searching for leaks. Use wood or cardboard instead of hands. Keep all components in good repair. Refer to owners manual if injury should occur. <p style="text-align: right; font-size: small;">666943</p>

<h2 style="margin: 0;">⚠ WARNING</h2>

<p>To avoid injury or death caused by falling loads:</p> <ul style="list-style-type: none"> Do not handle round bales unless loader is equipped with approved bale handling attachments. Handle raised loads with caution Carry load low Read operators manual
<h2 style="margin: 0;">⚠ WARNING</h2>

<p>To avoid injury from falls:</p> <ul style="list-style-type: none"> Do not work from or allow riders on loaders or its attachments <p>KOYKER MFG CO. INCLUDES ALL REASONABLE MEANS FOR ACCIDENT PREVENTION EXCEPT A SAFE AND CAREFUL OPERATOR.</p> <p style="text-align: right; font-size: x-small;">666944</p>

<h2 style="margin: 0;">⚠ WARNING</h2>

<p>To avoid injury from falling loader:</p> <ul style="list-style-type: none"> Do not walk or perform service under a raised loader. Lower loader to ground when parked. <p>KOYKER MFG CO. INCLUDES ALL REASONABLE MEANS FOR ACCIDENT PREVENTION EXCEPT A SAFE AND CAREFUL OPERATOR.</p> <p style="text-align: right; font-size: x-small;">666946</p>

<h2 style="margin: 0;">⚠ DANGER</h2>

<p>Serious injury or death can result from rollovers.</p> <ul style="list-style-type: none"> Use rops and seatbelt at all times. Add required rear ballast. Move wheels to widest recommended setting. Operate tractor at low seeds. Carry all loads close to ground.
<h2 style="margin: 0;">⚠ DANGER</h2>

<p>Serious injury or death can result from contact with electric lines.</p> <p>KOYKER MFG CO. INCLUDES ALL REASONABLE MEANS FOR ACCIDENT PREVENTION EXCEPT A SAFE AND CAREFUL OPERATOR.</p> <p style="text-align: right; font-size: x-small;">666945</p>

TRACTOR & SAFETY POINTERS

The use of good judgment and common sense is necessary by the operator in using this loader. The front and rear wheels should be set for the widest wheel tread to assure best stability. Use extra caution when rear wheel weights and tire ballast are added to a loader-equipped tractor. **DO NOT** ram into frozen dirt piles, frozen manure piles, ice, etc., with great momentum where sudden shock loads are encountered. Serious and costly damage may result to both the loader and the tractor.

When scraping or back dragging do not extend the attachment cylinders more than one half of the cylinder's stroke. A limited amount of leveling may be done, when the loader valving is arranged with a float control. This will prevent damage to cylinder rods. Never ride in the bucket.

Before operating the loader, be sure no one is standing near it. Only one person, the operator, should be on the tractor. Remain at the controls and under no circumstances leave the tractor unattended with the bucket in a raised position.

Never lift a person in the bucket or walk under a raised bucket.

Never drive your loader-equipped tractor down a hill that is steeper than 15 degrees. Carry all loads low and use care on side hills.

Always keep unused PTO shaft clutch levers disengaged.

Keep hands, feet, and clothing away from all moving parts.

Hydraulic oil, under pressure, can cause injury. Be sure that all connections are tight and that all pressure is relieved before disconnecting any lines.

Care must be taken with your loader cylinders. Nicks, scratches, rust, or other shaft damage can result in worn packing causing cylinder leakage and subnormal performance.

MOVE SLOWLY

USE COMMON SENSE

BE CAREFUL FOR YOUR OWN SAKE AND THAT OF OTHER PEOPLE

ATTACHING LOADER



IMPORTANT:

Never attempt to attach loader on grades which are not reasonably level.



Fig 8-1

1. Check to be sure that the surfaces of the mounts are free of obstructions.
2. Drive the tractor slowly and carefully in between the loader arms only far enough to permit coupling of the hydraulic system hoses. (Fig. 8-1)
3. Once all hoses have been properly coupled, drive the tractor slowly forward, watching to ensure that the bottom pivot cradle(s) clear the pivot pin(s), in the lower portion of the mount(s). (Fig. 8-2)
4. Allow the bottom pivot cradle(s) to settle onto the mount pivot pin(s). Slowly raise loader and dump bucket until both uprights are firmly located in the mounts. The back of the upright should be vertical. (Fig. 8-3)
5. To lock the loader onto the mount(s), install a 1-1/4" square mount pin (689302) through the square opening in the mount (both mounts). (Fig. 8-4)
6. Once the mount pin is completely engaged, lock the pin in place by positioning the mount pin handle through the slot opening in the mount retaining plate. (Fig. 8-5)



Fig 8-2



Fig 8-3



Fig 8-4



Fig 8-5

ATTACHING LOADER (continued)



IMPORTANT:

Never attempt to attach loader on grades which are not reasonably level.



Fig 9-1



Fig 9-2



Fig 9-3



Fig 9-4



Fig 9-5

7. To secure the loader to the mount, lower the mount wedge block into place by tightening the 12mm mount bolt at the back of the mount tower. (Fig. 9-1) Re-check bolts after first three hours of use.
8. After both uprights are secured to the mounts, raise the loader for leg stand removal and storage. Raise the loader until the loader bucket is approx. 24" off of the ground. (Fig 9-2)
9. With the bottom portion of leg stand supported, remove the 5/8" hitch pin (689571). (Fig 9-3)
10. Align the inner leg studs of the leg stand with the slots of the leg stand rail and slide the leg stand up the loader arm. (Fig 9-4)
11. Reinstall the 5/8" hitch pin (689571) as shown in Fig 9-5. The hitch pin will rest at the bottom of the leg stand rail.
12. Prior to operation, be certain to review all safety and operation information contained within this manual. Check mount bolts at the back of the mount tower after the first 3 hours of use and then check periodically during normal maintenance procedure.

ATTACHING JD 600 - 700 SERIES BUCKET

1. For attachment of the bucket, first tilt the bucket adapter forward so the cradles at the top of the adapter are below the cross bars on the back of the bucket. (Fig. 10-1). If the cradles do not line up with each other, tilt the bucket adapters rearward until they both once again in line and restart the procedure. While slowly driving forward, raise the loader and tilt the bucket adapter rearward until the adapter cradles come in contact with bucket cross bars. (Fig 10-2) Once **both** cradles are firmly engaged, continue to tilt the bucket adapter rearward until the lower mount pads of the adapters firmly contact the back of the bucket. (Fig 10-3) Carefully raise the latch pins (690020) off of their rest and allow them to engage, locking the bucket in place. (Fig 10-4) If the bucket is mounted with a grapple, auxiliary hydraulic lines will need to be connected prior to operation.

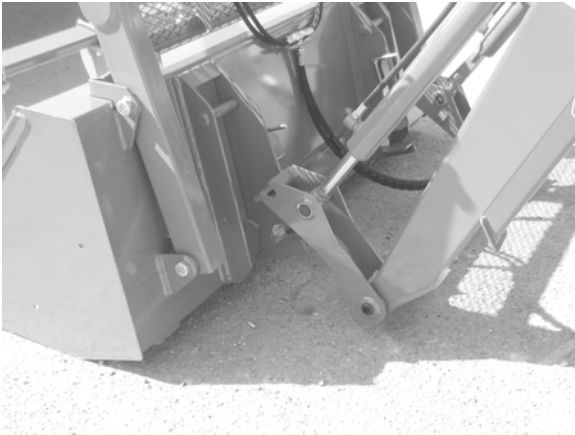

Fig 10-1



Fig 10-2



Fig 10-3



Fig 10-4

ATTACHING GLOBAL BUCKET

1. For attachment of the bucket, first tilt the bucket adapter forward so the adapter top bar is below the top hooks (mounts) on the back of the bucket. (Fig. 11-1). While slowly driving forward, raise the loader and tilt the bucket adapter rearward until the adapter come's in contact with bucket cross bars. (Fig 11-2) Once the adapter is firmly engaged, continue to tilt the bucket rearward until the lower mount pads of the adapter firmly contact the back of the bucket. (Fig 11-3) Carefully push the latch handles off of their rest or over center and allow them to engage, locking the bucket in place. (Fig 11-4) If the bucket is mounted with a grapple, auxiliary hydraulic lines will need to be connected prior to operation.



Fig 10-5



Fig 10-6



Fig 10-7



Fig 10-8

DETACHING LOADER



IMPORTANT:

Never attempt loader detachment on grades which are not reasonably level.



Fig 11-1



Fig 11-2



Fig 11-3



Fig 11-4

1. With the loader raised off of the ground, dump the bucket to approximately 40° degrees from level.
2. Disengage the mount wedge block by loosening the 12 mm mount bolt at the back of the mount tower. (Fig 11-1)
3. Slowly lower the loader until it contacts the ground and apply slight down pressure. DO NOT raise the front tractor tires off of the ground.
4. Remove the 5/8" hitch pin (689571) as shown in Fig (11-2). The hitch pin and allow the leg stand to slide down the leg stand rail.
5. Align the inner leg studs of the leg stand with the slots of the leg stand rail and rotate the leg stand rearward until the inner leg studs are outside the leg stand rail. (Fig 11-3)
6. Rotate the bottom of the leg stand rearward and align mount holes of the leg stand and loader arm. Install 5/8" hitch pin (689571). (Fig 11-4)

DETACHING LOADER (continued)



IMPORTANT:

Never attempt loader attachment on grades which are not reasonably level.



Fig 12-1



Fig 12-2



Fig 12-3

7. Remove the 1-1/4" square mount pin (689302) from the mount and upright of the loader. (Fig 12-1) Store the square mount pin vertically in the mount retaining plate.
8. With tractor in neutral and parking brake DISENGAGED extend the lift cylinders until there is approximately 2" between the back of the upright and the back of the mount. (Fig 12-2)
9. Slowly roll the bucket rearward until the leg stands contact the ground. Pay special attention that they both contact the ground evenly. If uneven ground is present, shim the leg stand with flat solid material. (Fig 12-3)
10. Continue to slowly roll the bucket rearward until the pivot cradle(s) of the upright(s) come off of the pivot pins of the mounts. One may need to slowly drive the tractor ahead as the uprights come out of the mount to keep slack in the hydraulic hoses to the loader. (Fig 12-4)
11. Retract the lift cylinders completely and detach the hydraulic hoses to the loader.



Fig 12-4

IMPORTANT:

Never store the detached loader where insufficient soil bearing capacity exists. Good firm clay or firmly packed dirt are sufficient, providing the area is dry. If you are unsure, use blocking under the stand foot to disperse the load. Failure to heed, may allow the loader to settle and prevent attachment at a later date.

DETACHING JD 600 - 700 SERIES BUCKET

1. If the bucket is mounted with a grapple the auxiliary hydraulic lines need to be disconnected prior to detachment of the bucket. For detachment of the bucket, first ensure the bucket is resting on flat ground. (Fig 13-1) Disengage the latch pins (690020) and position them onto their rest(s). (Fig 13-2) Slowly lower the loader while tilting the bucket adapters forward. (Fig 13-3) Drive rearward until both adapters have cleared the bucket. (Fig 13-4)



Fig 13-1



Fig 13-2



Fig 13-3



Fig 13-4

DETACHING GLOBAL BUCKET

1. If the bucket is mounted with a grapple the auxiliary hydraulic lines need to be disconnected prior to detachment of the bucket. For detachment of the bucket, first ensure the bucket is resting on flat ground. Disengage the handle latch pins (Fig 13-5) and position them onto their rest(s). (Fig 13-6) Slowly lower the loader while tilting the bucket adapter forward. (Fig 13-7) Drive rearward until global adapter has cleared the bucket. (Fig 13-8)



Fig 13-5



Fig 13-6



Fig 13-7



Fig 13-8

OPERATION



WARNING:

Never allow anyone to operate the loader until they have carefully reviewed and understood this owners manual.

FILLING THE BUCKET:

When manure is piled on a slope, it is best to drive tractor up the slope straight into the pile. Operating sideways on a slope has a tendency to tip the loading unit. Drive tractor straight into the pile, raise the bucket about six inches, then drop bucket and drive forward until the bucket is filled. Tilt bucket completely back, raise main frame and back away from manure pile.

DUMPING THE BUCKET:

When dumping, bring the bucket to proper dumping height which is just high enough so it will not strike the spreader as the load is being dumped. With the bucket tipped, drive tractor forward and raise the bucket at the same time to distribute the load evenly into spreader or conveyance.

RAISING THE BUCKET:



WARNING:

Make sure material in bucket cannot spill out on to tractor when loader boom is raised. Keep clear of overhead obstructions such as trees, limbs or power lines when raising the bucket.

Side cutting is the best method of reducing large stockpiles. If the sides of the pile are too high, use the loader to pull them down and reduce the possibility of slides.

Make sure you keep all lines, cylinders, and complete hydraulic system free of all sand, dirt, and foreign matter. Use only clean oil in the hydraulic system. When removing the loader from the tractor, be sure to plug all open ports. If the loader will be out of service for several days or longer, grease the exposed polished piston shafts on the bucket and the lift cylinders.

WARNING:



NEVER attempt to operate the loader with someone near the loader frame or bucket.

If this loader is equipped with a Grapple fork, be sure Grapple teeth are closed before leaving seat of tractor.

SPECIFICATIONS

Legend 640 SL SPECIFICATIONS

Description of Equipment Rated

Loader Model.....	640 SL
Lift Cylinder Dia.....	3-1/4" Bore
Attachment Cylinder Dia.....	2-1/2" Bore

Dimensional Specifications

(A) *Maximum Lift Height to Pivot Pin.....	12'-2"
(B) *Lift Height under Level Bucket.....	11'-5"
(C) *Clearance with Bucket Dumped @ 45°.....	9'- 2"
(D) *Reach at Maximum Lift Height.....	N/A
(E) Maximum Dump Angle.....	80°
(F) *Reach with Bucket on Ground.....	8'-2"
(G) Maximum Rollback Angle.....	38°
(H) *Digging Depth.....	7"
(J) *Overall Height in Carry Position.....	6'-3"

Operational Specifications

(U) *Lift Capacity to Maximum Height at Pivot Pin.....	3410 lbs.
(V) *Lift Capacity to Maximum Height 31.5" Forward of Pivot Pin.....	N/A lbs.
(Y) *Breakout Force at Ground Line at Pivot Pin.....	5890 lbs.
(Z) *Breakout Force at Ground Line 31.5" Forward of Pivot Pin.....	N/A lbs.

*Specifications based on ASABE standards S301.3 (Front-End Agricultural Loader Ratings) Variations in maximum lift height and other specs for different tractors are due to tire sizes, variations in loader mounting locations and hydraulic system efficiency.

Specifications are subject to change without notice and without liability therefore.

SPECIFICATIONS

Legend 640 NSL SPECIFICATIONS

Description of Equipment Rated

Loader Model.....	640 NSL
Lift Cylinder Dia.....	3-1/4" Bore
Attachment Cylinder Dia.	2-1/2" Bore

Dimensional Specifications

(A) *Maximum Lift Height to Pivot Pin.....	12'-2"
(B) *Lift Height under Level Bucket.....	11'-5"
(C) *Clearance with Bucket Dumped @ 39°.....	10'-0"
(D) *Reach at Maximum Lift Height.....	N/A
(E) Maximum Dump Angle.....	39°
(F) *Reach with Bucket on Ground.....	8'-2"
(G) Maximum Rollback Angle.....	15°
(H) *Digging Depth.....	7"
(J) *Overall Height in Carry Position.....	6'-3"

Operational Specifications

(U) *Lift Capacity to Maximum Height at Pivot Pin.....	3300 lbs.
(V) *Lift Capacity to Maximum Height 31.5" Forward of Pivot Pin.....	N/A lbs.
(Y) *Breakout Force at Ground Line at Pivot Pin.....	5800 lbs.
(Z) *Breakout Force at Ground Line 31.5" Forward of Pivot Pin.....	N/A lbs.

*Specifications based on ASABE standards S301.3 (Front-End Agricultural Loader Ratings) Variations in maximum lift height and other specs for different tractors are due to tire sizes, variations in loader mounting locations and hydraulic system efficiency.

Specifications are subject to change without notice and without liability therefore.

LOADER INSPECTION, SERVICE AND MAINTENANCE

Lower the bucket to the ground, shut off tractor engine and relieve the pressure in the hydraulic system before adjusting, lubricating or servicing the loader.

Inspect all pins and grease fittings before each use and lubricate with heavy duty grease as indicated in this manual.

Periodically check all bolts for looseness and re-torque if necessary.

Before storage, be certain all hydraulic cylinders are fully collapsed so that the rod will not be exposed to the elements or damaged.

Be certain hydraulic system remains sealed at all times to prevent contamination.

Check and maintain an adequate fluid level in the tractor reservoir prior to use.

Inspect all hydraulic system hoses and fittings. Replace prior to further operation if damaged.



WARNING!

Escaping hydraulic oil under pressure can penetrate the skin. Never use body to check for hydraulic leaks. Use cardboard when checking for leaks. See Fig. 13-1. Relieve hydraulic pressure before disconnecting any hydraulic line. Failure to heed may result in serious injury or death.

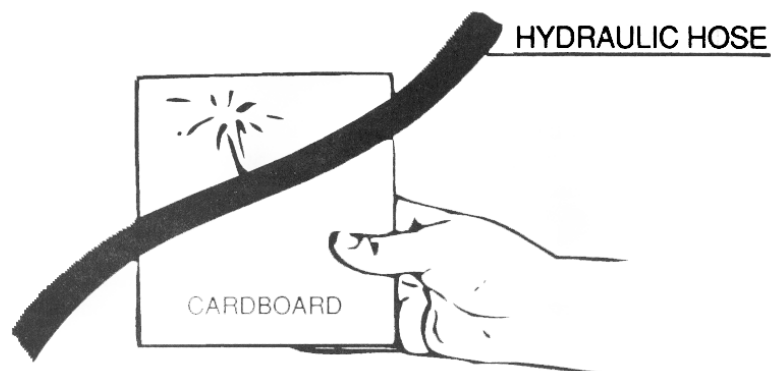
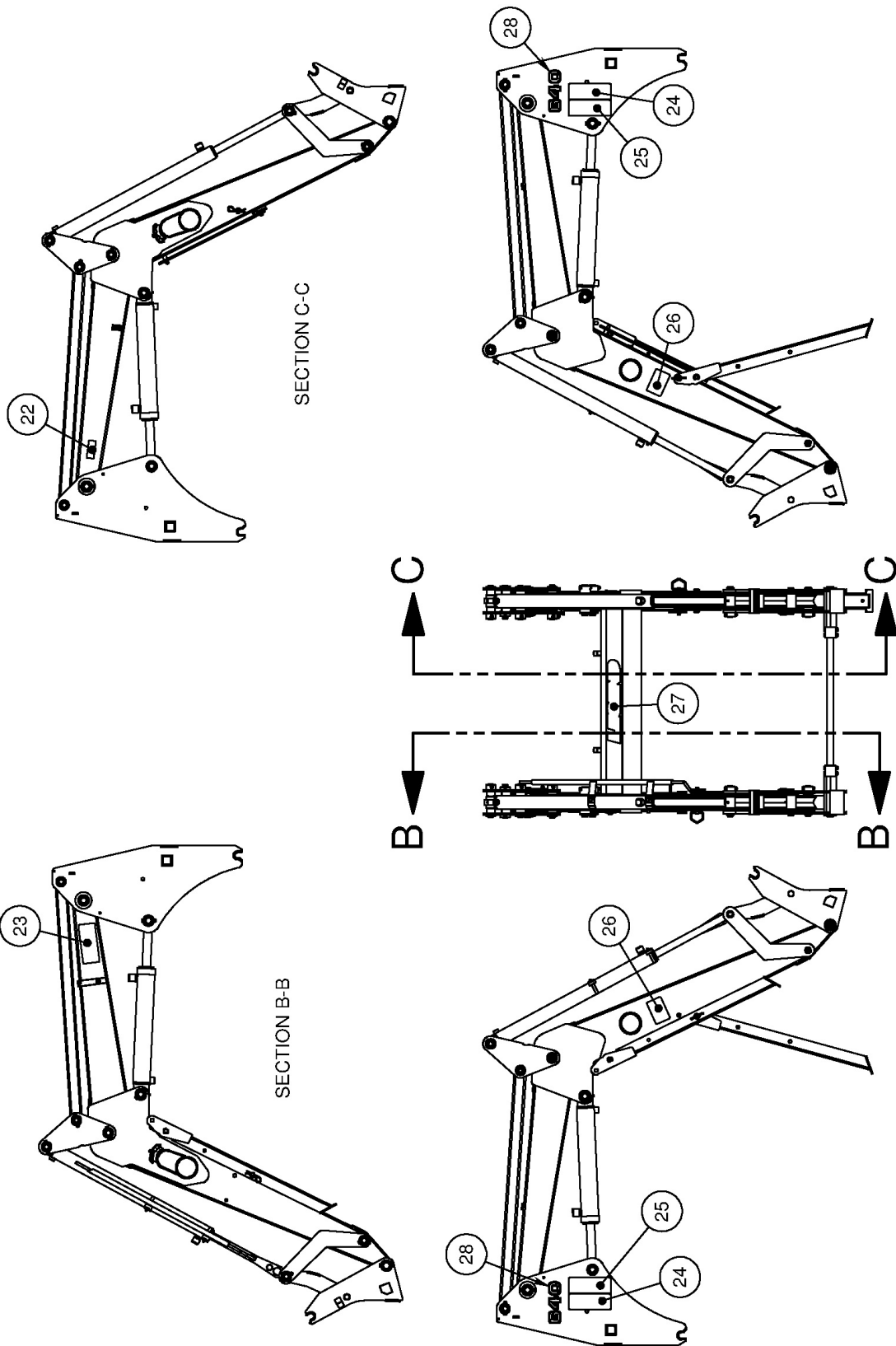

FIG. 13-1

640 SL LOADER PARTS DIAGRAM - (continued)



640 SL PARTS IDENTIFICATION SCHEDULE

ITEM NO.	PART NUMBER	DESCRIPTION	MAIN ASS./QTY.
1	689444	LH LEVELING PLATE WLDT	1
2	689481	RH LEVELING PLATE WLDT	1
3	689554	ADAPTER SHAFT	1
4	689913	LEG STAND RAIL WLDT	2
5	689915	INDICATOR ROD WLDT	1
6	689926	3 1/4" LIFT CYLINDER ASSEMBLY (640 NSL)	2
7	689933	INDICATOR SLEEVE WLDT	1
8	689935	LEG STAND WLDT	2
9	690901	MAINFRAME WLDT	1
10	690903	2 1/2" BUCKET CYLINDER ASSEMBLY (640 SL)	2
11	690916	LEVELING ARM WLDT	2
12	690920	UPRIGHT WLDT	2
13	690921	REAR LINKAGE PLATE	2
14	690922	RIGHT REAR LINKAGE WLDT	1
15	690923	LEFT LINKAGE WLDT	1
16	690924	LH ADAPTER & LINKAGE WLDT	1
17	690925	RH ADAPTER & LINKAGE WLDT	1
18	690935	ADAPTER WASHER PLATE	4
19	690937	SPACER - 1.25 X 1.75 X 1.00	4
20	689952	LPACKAGE - LDR 640 HARDLINES	1
21	690938	LPACKAGE - LDR 640 SL HOSES	1
22	666941	SERIAL NUMBER DECAL	1
23	666943	HYDRAULIC PRESSURE DECAL	1
24	666944	WARNING DECAL	2
25	666945	"DANGER DECAL"	2
26	666946	WARNING DECAL	2
27	689639	"LEGEND" DECAL - JOHN DEERE	1
28	689880	"640" DECAL	2
29	689472	PIVOT PIN - 1.375 X 9.625 - GREASEABLE	2
30	689474	PIVOT PIN - 1.375 X 6.375	6
31	689475	PIVOT PIN - 1.1875 X 6.344 - GREASEABLE	2
32	689476	PIVOT PIN - 1.1875 X 6.469	2

640 SL PARTS IDENTIFICATION SCHEDULE - (continued)

ITEM NO.	PART NUMBER	DESCRIPTION	MAIN ASS./QTY.
33	689477	PIVOT PIN - 1.1875 X 7.1875 - GREASEABLE	2
34	689478	PIVOT PIN - 1.1875 X 7.065	6
35	689553	PIVOT PIN - .75 X 5	2
36	689571	HITCH PIN - .625 X 4.25	2
37	640032	SCREW-.375-16 X 1.25 GR 5 HHC	4
38	640039	SCREW-.375-16 X 2.50 GR 5 HHC	12
39	680199	SCREW-.375-16 X 2.75 GR 5 HHC	10
40	640154	WASHER - 3/8" FLAT	3
41	657632	ZERK-1/4-28 GREASE	14
42	689954	2.56 - 3.50 HOSE CLAMP	2
43	690800	OIL LINE CLAMP	2
44	690801	HOSE LINE CLAMP	2
45	689488	3/4" "E" CLIP	4
46	689567	OIL LINE CLAMP - 6 LINES	2
47	689578	1 3/16" EXTERNAL SNAP RING	6
48	700560	NUT - .375-16 GR 2 CENTER LOCK	26
49	672503	OIL LINE CLAMP TWIN .500	2

640 SL GLOBAL LOADER PARTS DIAGRAM

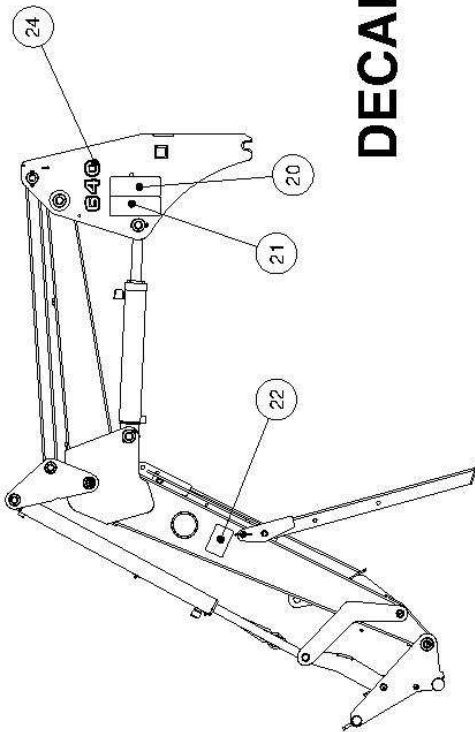
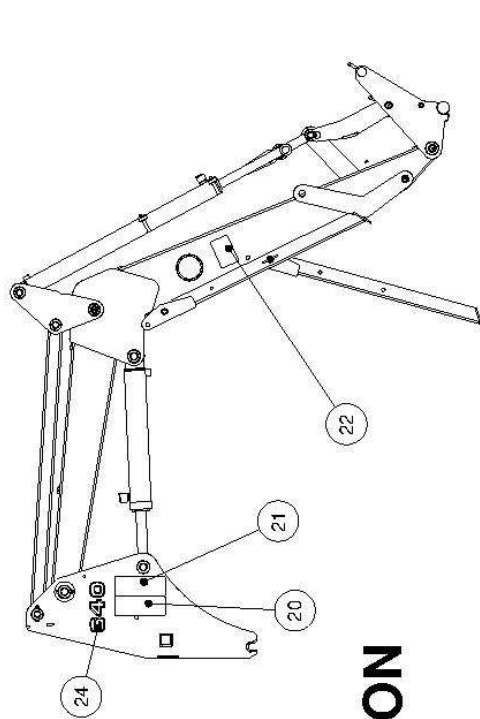

DECAL LOCATION

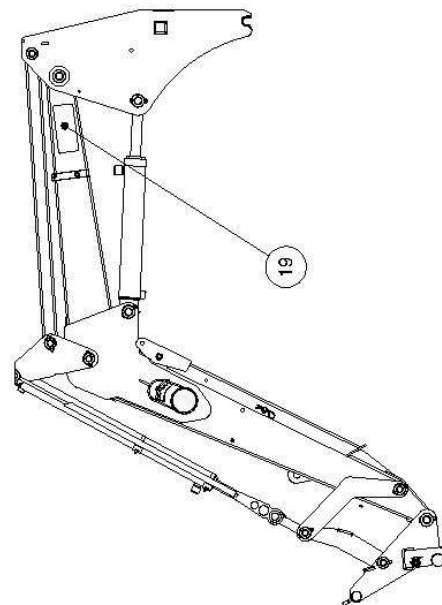
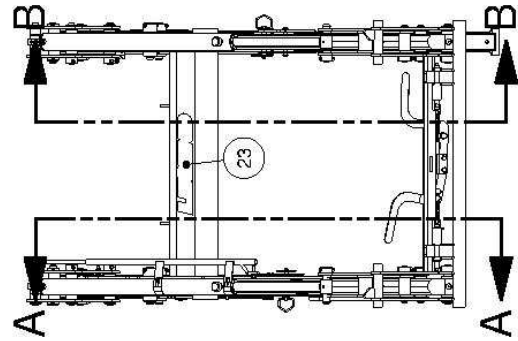
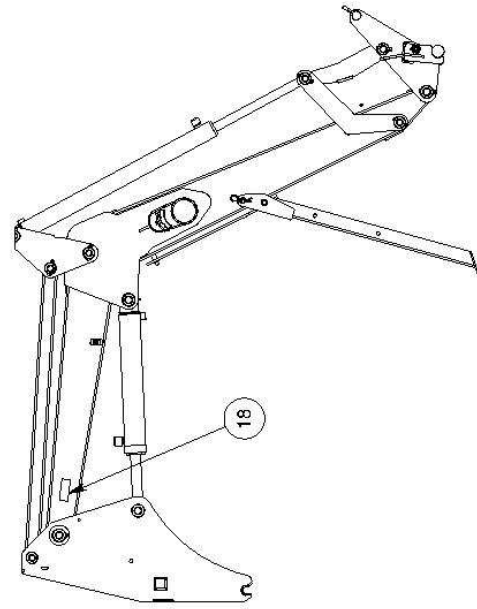

SECTION B-B

SECTION A-A

640 SL GLOBAL PARTS IDENTIFICATON SCHEDULE

ITEM NO.	DESCRIPTION	PART NUMBER	QTY
1	LH LEVELING PLATE WLDT	689444	1
2	RH LEVELING PLATE WLDT	689481	1
3	LEG STAND RAIL WLDT	689913	2
4	INDICATOR ROD WLDT	689915	1
5	3 1/4" LIFT CYLINDER ASSEMBLY (640 NSL)	689926	1
6	3 1/4" LIFT CYLINDER ASSEMBLY (640 NSL)	689926	1
7	INDICATOR SLEEVE WLDT	689933	1
8	LEG STAND WLDT	689935	2
9	MAINFRAME WLDT	690901	1
10	LEVELING ARM WLDT	690916	2
11	UPRIGHT WLDT	690920	2
12	REAR LINKAGE PLATE	690921	2
13	RIGHT REAR LINKAGE WLDT	690922	1
14	LEFT LINKAGE WLDT	690923	1
15	SPACER - 1.25 X 1.75 X 1.00	690937	4
16	LPACKAGE - LDR 640 HARDLINES	689952	1
17	LPACKAGE - LDR 640 SL HOSES	690938	1
18	SERIAL NUMBER DECAL	666941	1
19	HYDRAULIC PRESSURE DECAL	666943	1
20	WARNING DECAL	666944	2
21	"DANGER DECAL"	666945	2
22	WARNING DECAL	666946	2
23	"LEGEND" DECAL - JOHN DEERE	689639	1
24	"640" DECAL	689880	2
25	PIVOT PIN - 1.375 X 6.375	689474	6
26	PIVOT PIN - 1.1875 X 6.344 - GREASEABLE	689475	2
27	PIVOT PIN - 1.1875 X 6.469	689476	2
28	PIVOT PIN - 1.1875 X 7.1875 - GREASEABLE	689477	2
29	PIVOT PIN - 1.1875 X 7.065	689478	6
30	PIVOT PIN - .75 X 5	689553	2
31	HITCH PIN - .625 X 4.25	689571	2
32	SCREW-.375-16 X 1.25 GR 5 HHC	640032	4
33	SCREW-.375-16 X 2.50 GR 5 HHC	640039	12
34	SCREW-.375-16 X 2.75 GR 5 HHC	680199	6
35	WASHER - 3/8" FLAT	640154	3
36	ZERK-1/4-28 GREASE	657632	14
37	OIL LINE CLAMP TWIN .500	672503	2
38	2.56 - 3.50 HOSE CLAMP	689954	2
39	OIL LINE CLAMP	690800	2
40	3/4" "E" CLIP	689488	4
41	OIL LINE CLAMP - 6 LINES	689567	2
42	1 3/16" EXTERNAL SNAP RING	689578	6
43	NUT - .375-16 GR 2 CENTER LOCK	700560	22
44	2 1/2" BUCKET CYLINDER ASSEMBLY (640 SL)	690903	2
46	ADAPTER WASHER PLATE	690935	4

640 SL GLOBAL PARTS IDENTIFICATON SCHEDULE (continued)

ITEM NO.	DESCRIPTION	PART NUMBER	QTY
47	640 SL GLOBAL MOUNT ASM	690364	1
47.1	640 SL GLOBAL MOUNT WELDMENT	690367	1
47.2	PIVOT PIN - .79" (20MM) X 8"	679304	2
47.3	COMPRESSION SPRING	675323	2
47.4	PIN 1 X 2 ZINK PLATED	690422	1
47.5	PIN 1 X 1.625 GLOBAL MOUNT	690421	1
47.6	CLEVIS PIN .5" X 1.5"	680761	2
47.7	COTTER PIN - .156 X 1.50	680768	2
47.8	PIN 1.375 X 6.75 GLOBAL MOUNT	690317	2
47.9	WASHER - 1/2" FLAT N-SERIES	653098	4
47.10	1" EXTERNAL SNAP RING	690326	4
47.11	SCREW-.375-16 X 2.75 GR 5 HHC	680199	2
47.12	NUT - .375-16 GR 2 CENTER LOCK	700560	4
47.13	ZERK-1/4-28 GREASE	657632	6
47.14	PIVOT PIN - 1.1875 X 6.344 - GREASEABLE	689475	2
47.15	SCREW-.375-16 X 2.50 GR 5 HHC	640039	2
47.16	HANDLE RH	690346	1
47.17	HANDLE LH	690351	1
47.18	SCREW-.50-13 X 2.50 GR 5 HHC ZP	163752	2
47.19	NUT - .500-13 GR 2 HEX	640139	2
47.20	HOOK UP .5" PIN	690353	2
47.21	FRONT LINKAGE WLDT	690929	2
47.22	NUT - .500 - 20 GR 2 THIN FLEX	659885	2
48	HOSE LINE CLAMP	690801	2

640 SL LOADER HYDRAULIC PARTS DIAGRAM

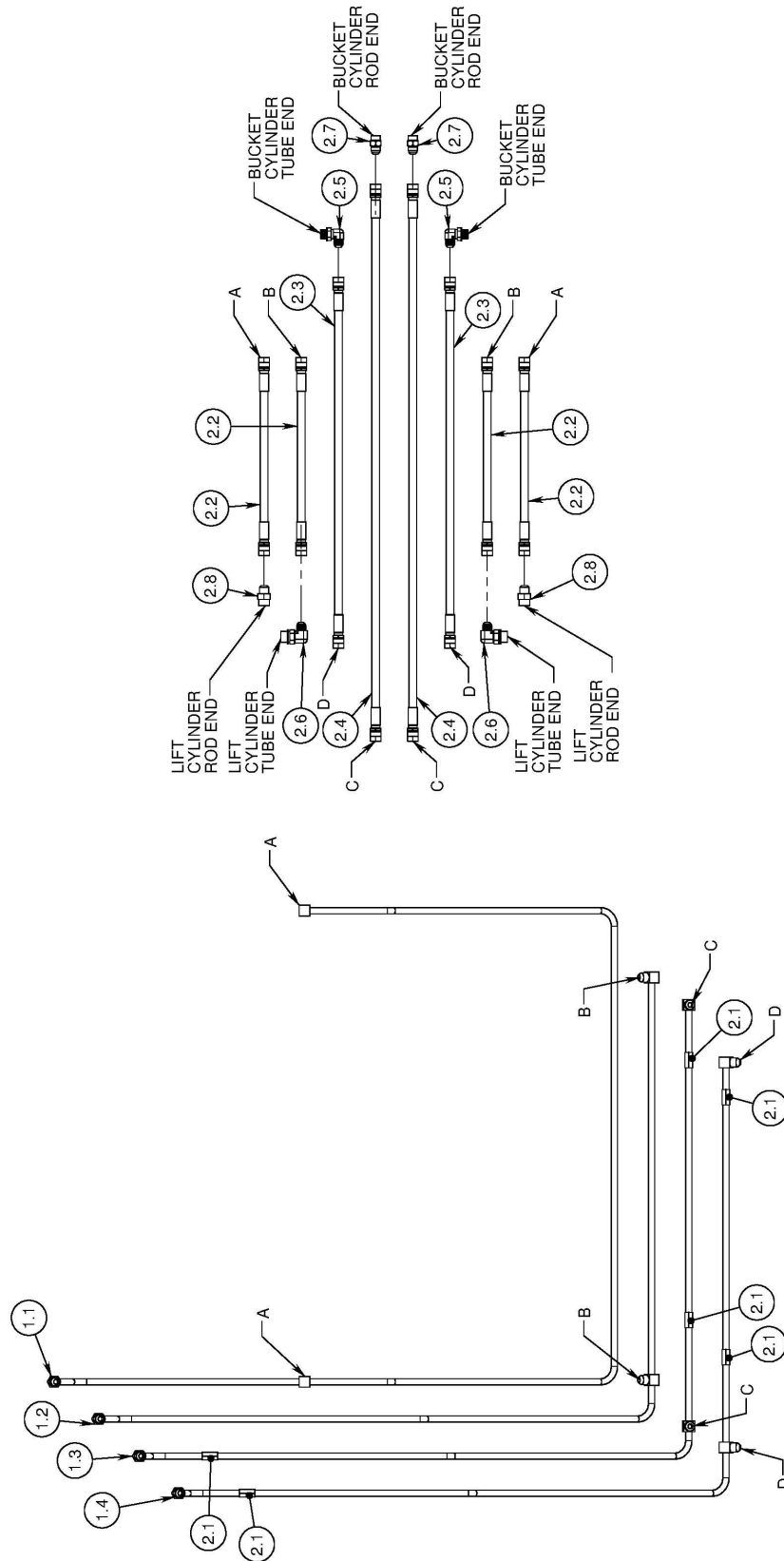

640 SL HYDRAULIC PARTS IDENTIFICATON SCHEDULE

ITEM NO.	PART NUMBER	DESCRIPTION	QTY.
1	689952	LPACKAGE - LDR 640 HARDLINES	1
1.1		LIFT CYL RETRACT OIL LINE #6	1
1.2		LIFT CYL EXTEND OIL LINE #5	1
1.3		BUCKET CYL RETRACT OIL LINE #4	1
1.4		BUCKET CYL EXTEND OIL LINE #3	1
2	690938	LPACKAGE - LDR 640 SL HOSES	1
2.1	689645	OIL LINE SPACER - 1/2"	6
2.2	689919	HOSE - KLM6R16-8FJX-8FJX-16	4
2.3	690939	HOSE - KLM6R16-8FJX-8FJX-30	2
2.4	690940	HOSE - KLM6R16-8FJX-8JFX-45	2
2.5	659838	FITTING - HYD ADA 8MJX - 10ORM	2
2.6	663201	FITTING-HYD 90 ELB 8 MJX - 8 ORM	2
2.7	675513	FITTING -HYD 90 ELB 8MJIC - 10 ORM - (6801-8-10)	2
2.8	675515	FITTING - HYD ADA 8MJX - 8 ORM	2

640 NSL LOADER PARTS DIAGRAM

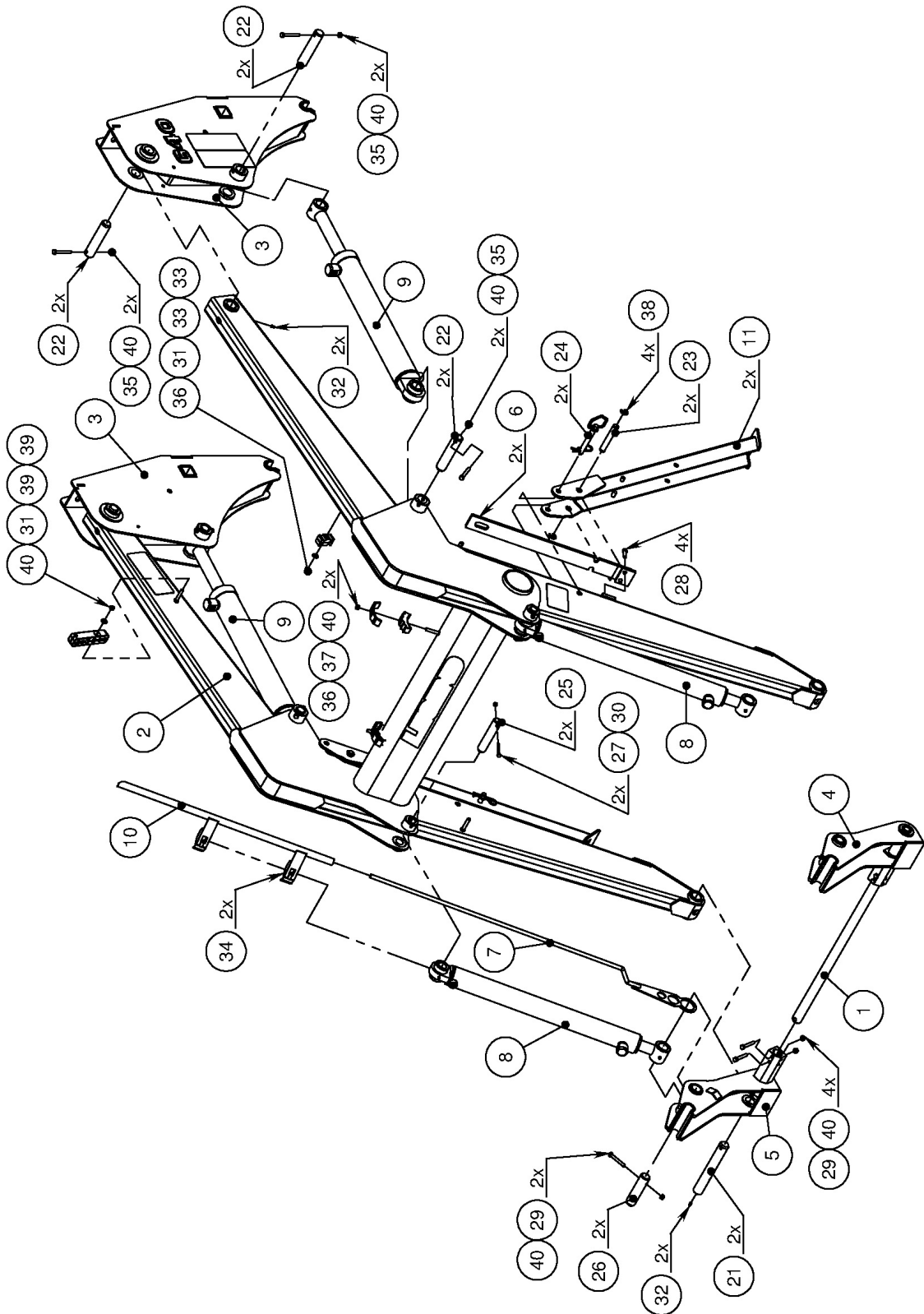

640 NSL LOADER PARTS DIAGRAM - (continued)

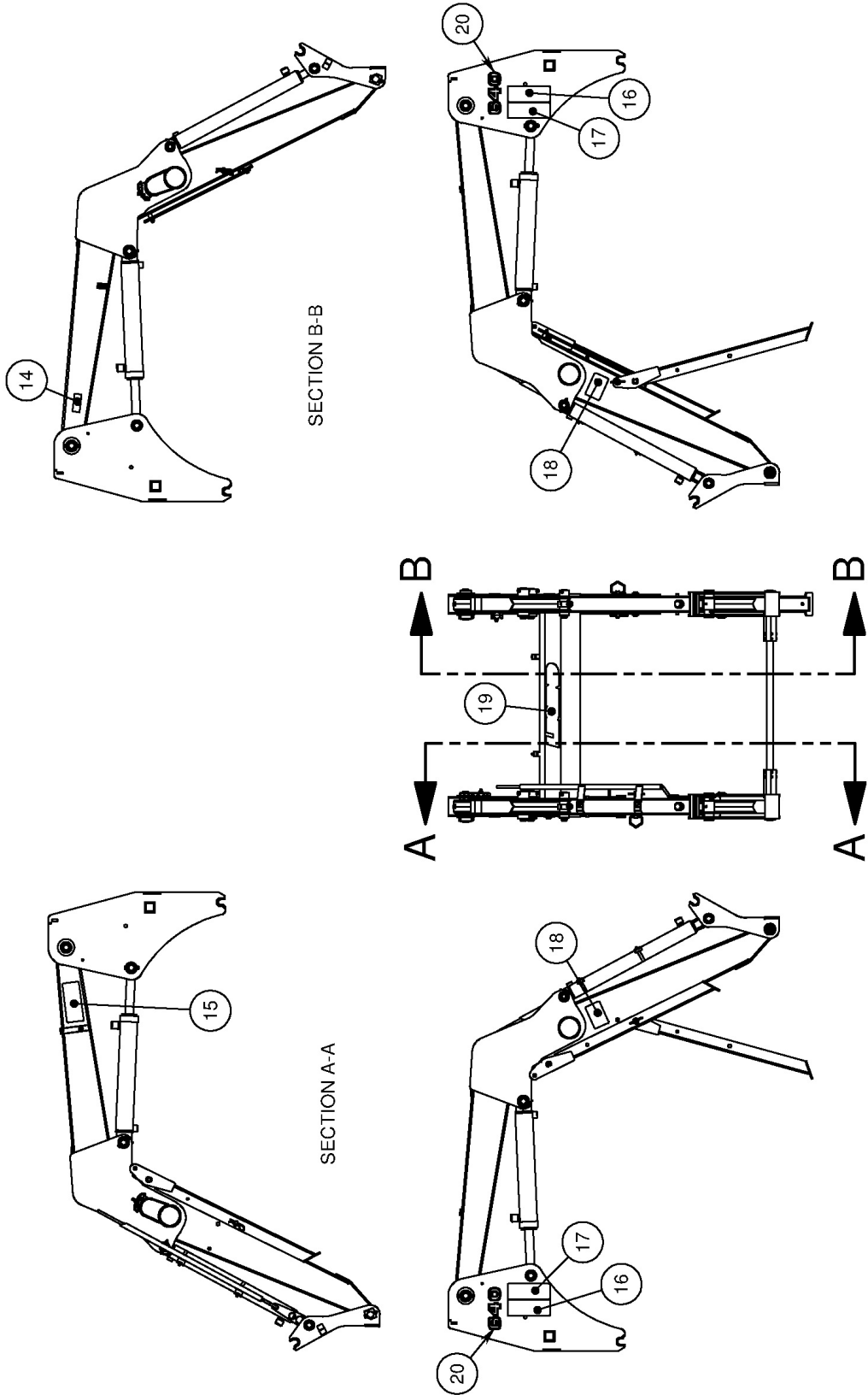

640 NSL PARTS IDENTIFICATION SCHEDULE

ITEM NO.	PART NUMBER	DESCRIPTION	MAIN ASS./QTY.
1	689554	ADAPTER SHAFT	1
2	689890	MAINFRAME WLDT	1
3	689910	UPRIGHT WLDT	2
4	689911	LH ADAPTER WLDT	1
5	689912	RH ADAPTER WLDT	1
6	689913	LEG STAND RAIL WLDT	2
7	689915	INDICATOR ROD WLDT	1
8	689920	2 1/2" BUCKET CYLINDER ASSEMBLY (640 NSL)	2
9	689926	3 1/4" LIFT CYLINDER ASSEMBLY (640 NSL)	2
10	689933	INDICATOR SLEEVE WLDT	1
11	689935	LEG STAND WLDT	2
12	689952	LPACKAGE - LDR 640 HARDLINES	1
13	689953	LPACKAGE - LDR 640 NSL HOSES	1
14	666941	SERIAL NUMBER DECAL	1
15	666943	HYDRAULIC PRESSURE DECAL	1
16	666944	WARNING DECAL	2
17	666945	"DANGER DECAL"	2
18	666946	WARNING DECAL	2
19	689639	"LEGEND" DECAL - JOHN DEERE	1
20	689880	"640" DECAL	2
21	689472	PIVOT PIN - 1.375 X 9.625 - GREASEABLE	2
22	689474	PIVOT PIN - 1.375 X 6.375	6
23	689553	PIVOT PIN - .75 X 5	2
24	689571	HITCH PIN - .625 X 4.25	2
25	689881	PIVOT PIN - 1.125 X 6.00	2
26	689882	PIVOT PIN - 1.375 X 5.50	2
27	640010	SCREW-.250-20 X 2.50 GR 5 HHC	2
28	640032	SCREW-.375-16 X 1.25 GR 5 HHC	4
29	640039	SCREW-.375-16 X 2.50 GR 5 HHC	6
30	640126	NUT - .25-20 GR 2 CENTER LOCK	2
31	640154	WASHER - 3/8" FLAT	3
32	657632	ZERK-1/4-28 GREASE	4

640 NSL PARTS IDENTIFICATON SCHEDULE - (continued)

ITEM NO.	PART NUMBER	DESCRIPTION	MAIN ASS./QTY.
33	672503	OIL LINE CLAMP TWIN .500	2
34	689954	2.56 - 3.50 HOSE CLAMP	2
35	680199	SCREW-.375-16 X 2.75 GR 5 HHC	6
36	690800	OIL LINE CLAMP	2
37	690801	HOSE LINE CLAMP	2
38	689488	3/4" "E" CLIP	4
39	689567	OIL LINE CLAMP - 6 LINES	2
40	700560	NUT - .375-16 GR 2 CENTER LOCK	16

640 NSL GLOBAL LOADER PARTS DIAGRAM

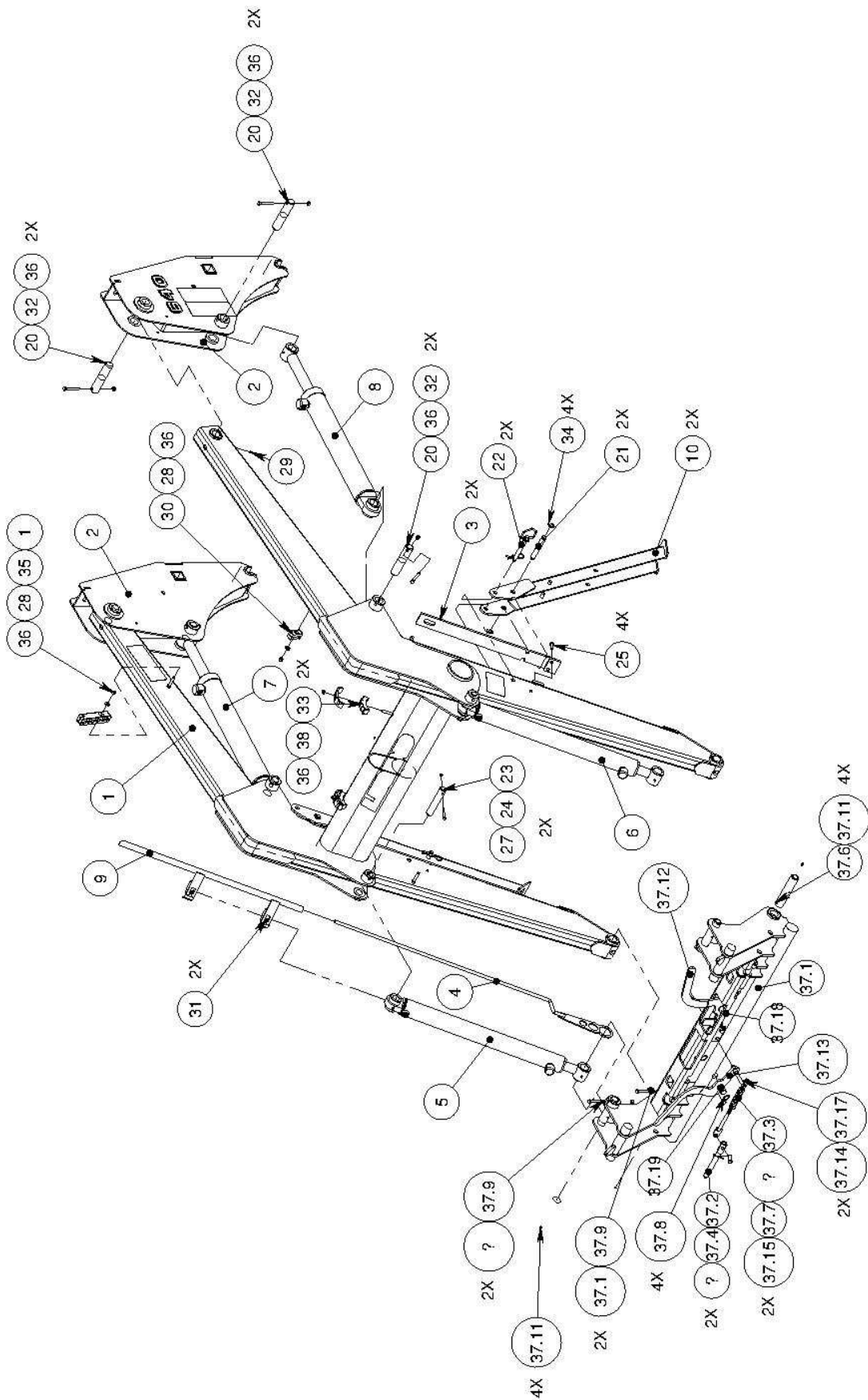

640 NSL GLOBAL LOADER PARTS DIAGRAM - (continued)

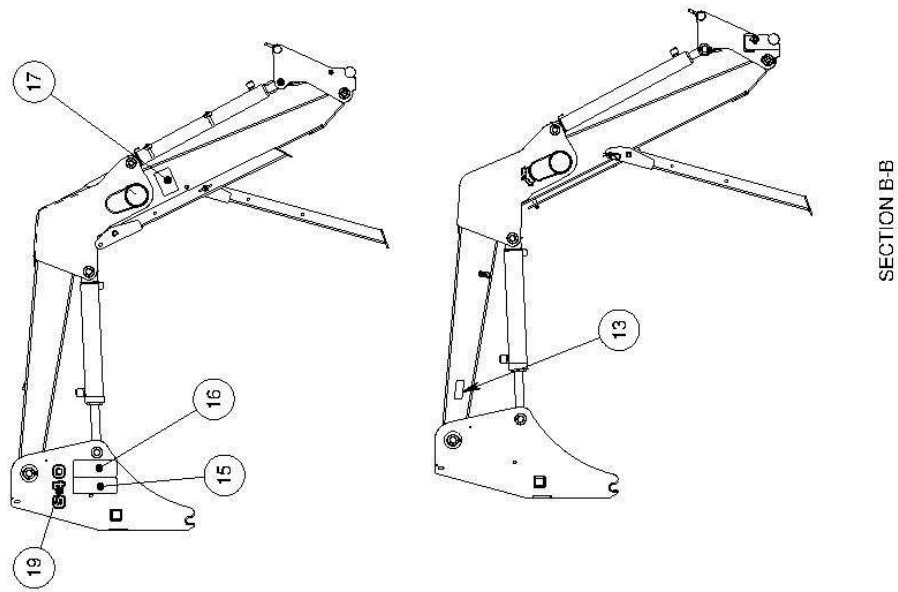

DECAL LOCATION

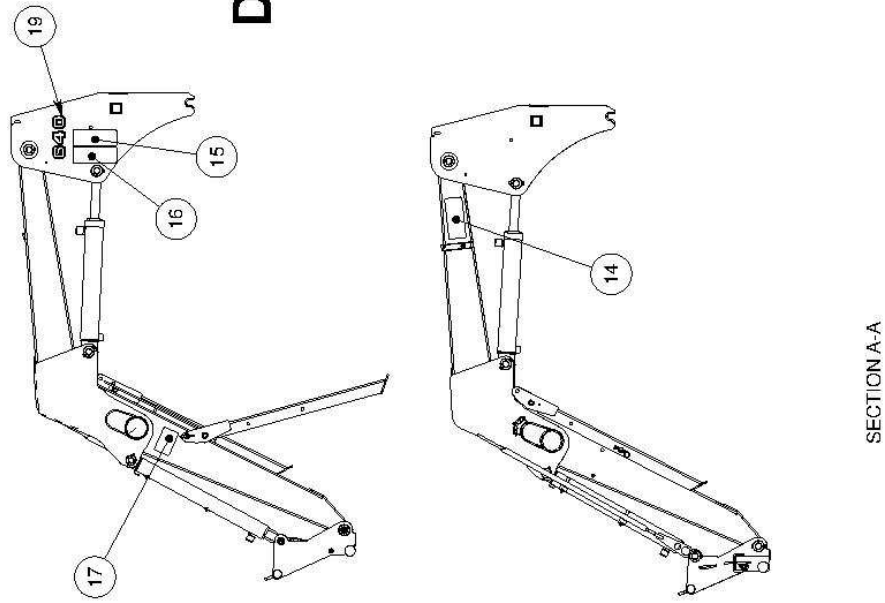
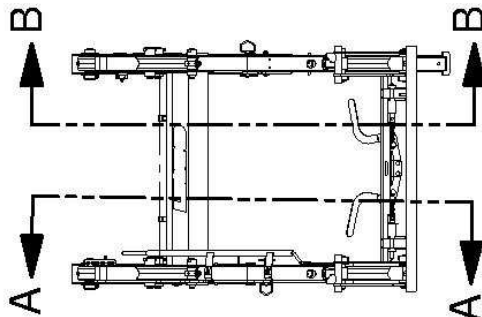

640 NSL GLOBAL PARTS IDENTIFICATON SCHEDULE

ITEM NO.	PART NUMBER	DESCRIPTION	QTY
1	689890	MAINFRAME WLDT	1
2	689910	UPRIGHT WLDT	2
3	689913	LEG STAND RAIL WLDT	2
4	689915	INDICATOR ROD WLDT	1
5	689920	2 1/2" BUCKET CYLINDER ASSEMBLY (640 NSL)	1
6	689920	2 1/2" BUCKET CYLINDER ASSEMBLY (640 NSL)	1
7	689926	3 1/4" LIFT CYLINDER ASSEMBLY (640 NSL)	1
8	689926	3 1/4" LIFT CYLINDER ASSEMBLY (640 NSL)	1
9	689933	INDICATOR SLEEVE WLDT	1
10	689935	LEG STAND WLDT	2
11	689952	LPACKAGE - LDR 640 HARDLINES	1
12	689953	LPACKAGE - LDR 640 NSL HOSES	1
13	666941	SERIAL NUMBER DECAL	1
14	666943	HYDRAULIC PRESSURE DECAL	1
15	666944	WARNING DECAL	2
16	666945	"DANGER DECAL"	2
17	666946	WARNING DECAL	2
18	689639	"LEGEND" DECAL - JOHN DEERE	1
19	689880	"640" DECAL	2
20	689474	PIVOT PIN - 1.375 X 6.375	6
21	689553	PIVOT PIN - .75 X 5	2
22	689571	HITCH PIN - .625 X 4.25	2
23	689881	PIVOT PIN - 1.125 X 6.00	2
24	640010	SCREW-.250-20 X 2.50 GR 5 HHC	2
25	640032	SCREW-.375-16 X 1.25 GR 5 HHC	4
26	640039	SCREW-.375-16 X 2.50 GR 5 HHC	2
27	640126	NUT - .25-20 GR 2 CENTER LOCK	2
28	640154	WASHER - 3/8" FLAT	3
29	657632	ZERK-1/4-28 GREASE	3
30	672503	OIL LINE CLAMP TWIN .500	2
31	689954	2.56 - 3.50 HOSE CLAMP	2

640 NSL GLOBAL PARTS IDENTIFICATON SCHEDULE - (continued)

ITEM NO.	PART NUMBER	DESCRIPTION	QTY
32	680199	SCREW-.375-16 X 2.75 GR 5 HHC	6
33	690800	OIL LINE CLAMP	2
34	689488	3/4" "E" CLIP	4
35	689567	OIL LINE CLAMP - 6 LINES	2
36	700560	NUT - .375-16 GR 2 CENTER LOCK	12
37	690363	640 NSL GLOBAL	1
37.1	690368	640 NSL GLOBAL MOUNT WELDMENT	1
37.2	679304	PIVOT PIN - .79" (20MM) X 8"	2
37.3	675323	COMPRESSION SPRING	2
37.4	680761	CLEVIS PIN .5" X 1.5"	2
37.5	680768	COTTER PIN - .156 X 1.50	2
37.6	690317	PIN 1.375 X 6.75 GLOBAL MOUNT	4
37.7	653098	WASHER - 1/2" FLAT N-SERIES	4
37.8	690326	1" EXTERNAL SNAP RING	4
37.9	680199	SCREW-.375-16 X 2.75 GR 5 HHC	4
37.10	700560	NUT - .375-16 GR 2 CENTER LOCK	4
37.11	657632	ZERK-1/4-28 GREASE	6
37.12	690346	HANDLE RH	1
37.13	690351	HANDLE LH	1
37.14	640139	NUT - .500-13 GR 2 HEX	2
37.15	690353	HOOK UP .5" PIN	2
37.16	659885	NUT - .500 - 20 GR 2 THIN FLEX	2
37.17	663701	SCREW-.50-13 X 2.75 GR 5 HHC	2
37.18	690422	PIN 1 X 2 ZINK PLATED	1
37.19	690421	PIN 1 X 1.625 GLOBAL MOUNT	1
38	690801	HOSE LINE CLAMP	2

640 NSL LOADER HYDRAULIC PARTS DIAGRAM

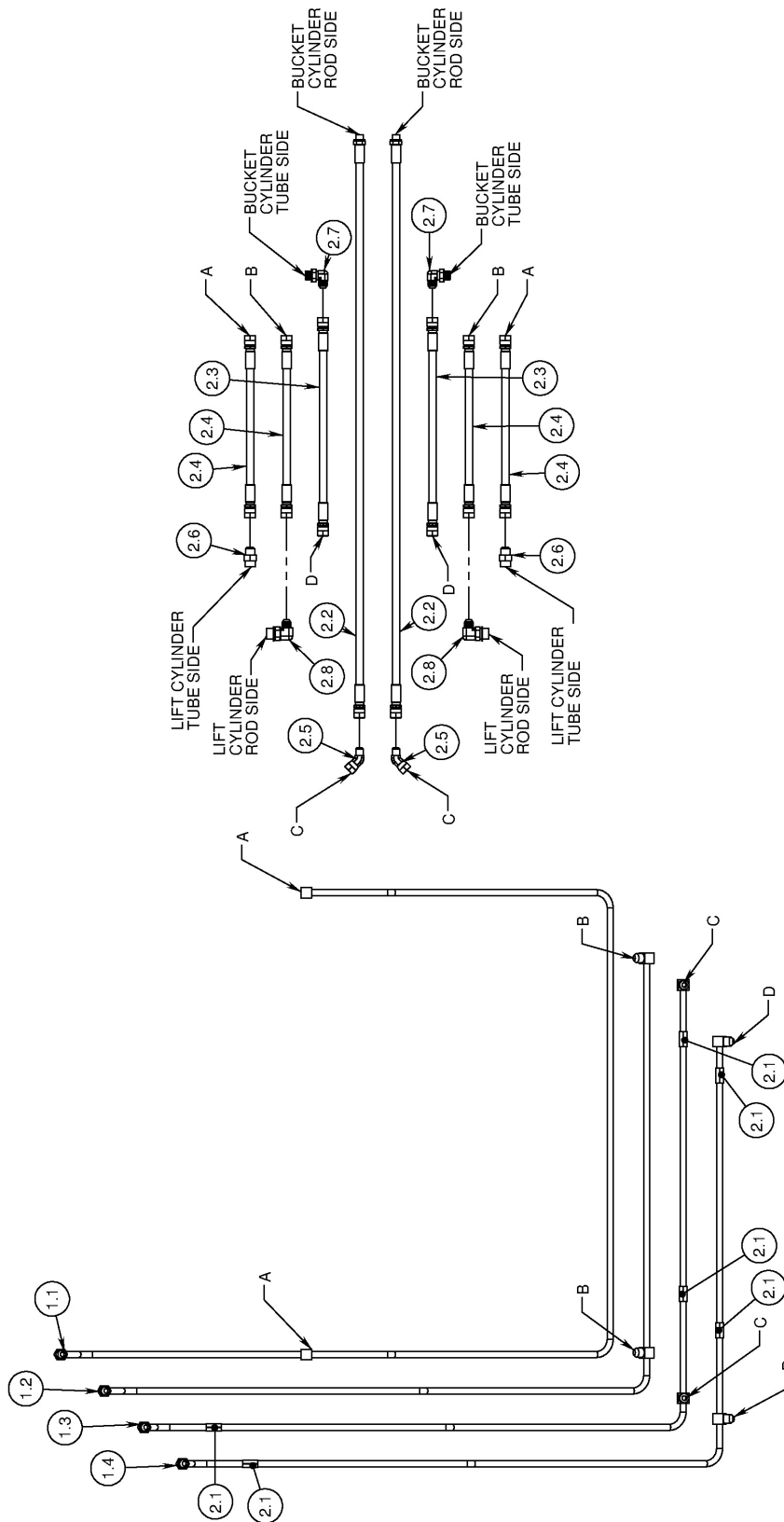

640 NSL HYDRAULIC PARTS IDENTIFICATON SCHEDULE

ITEM NO.	PART NUMBER	DESCRIPTION	QTY.
1	689952	LPACKAGE - LDR 640 HARDLINES	1
1.1		LIFT CYL RETRACT OIL LINE #6	1
1.2		LIFT CYL EXTEND OIL LINE #5	1
1.3		BUCKET CYL RETRACT OIL LINE #4	1
1.4		BUCKET CYL EXTEND OIL LINE #3	1
2	689953	LPACKAGE - LDR 640 NSL HOSES	1
2.1	689645	OIL LINE SPACER - 1/2"	6
2.2	689917	HOSE - KLM6R16-8FJX-8MBO-48	2
2.3	689918	HOSE - KLM6R16-8FJX-8FJX-18	2
2.4	689919	HOSE - KLM6R16-8FJX-8FJX-16	4
2.5	652448	45 ELBOW 8FJX-8MJX	2
2.6	659838	FITTING - HYD ADA 8MJX - 10ORM	2
2.7	663201	FITTING-HYD 90 ELB 8 MJX - 8 ORM	2
2.8	675513	FITTING -HYD 90 ELB 8MJIC - 10 ORM - (6801-8-10)	2

JD 600 - 700 SERIES BUCKET PARTS DIAGRAM

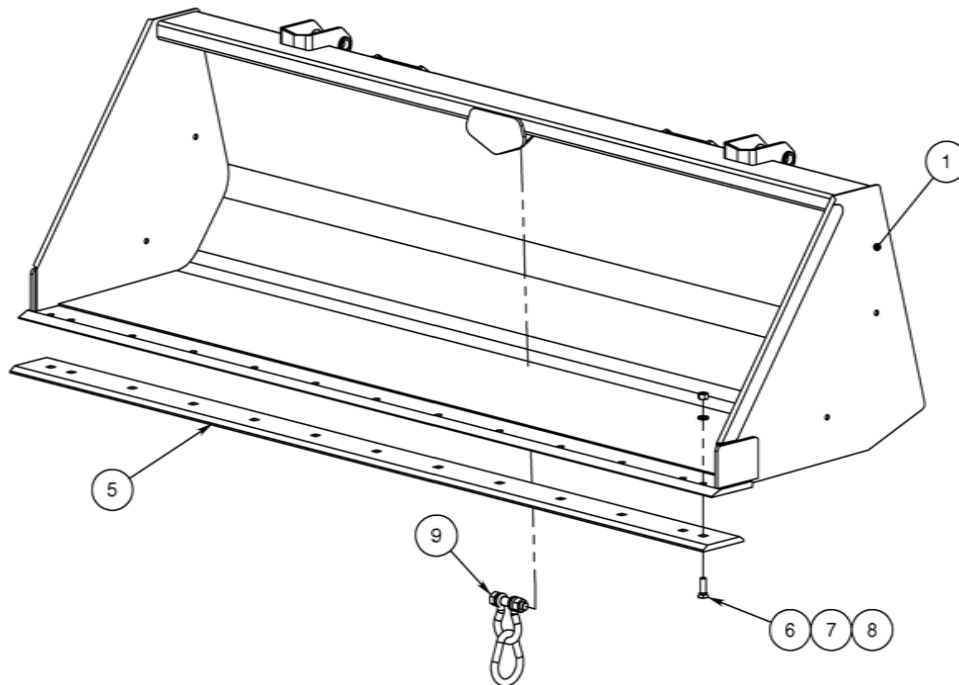
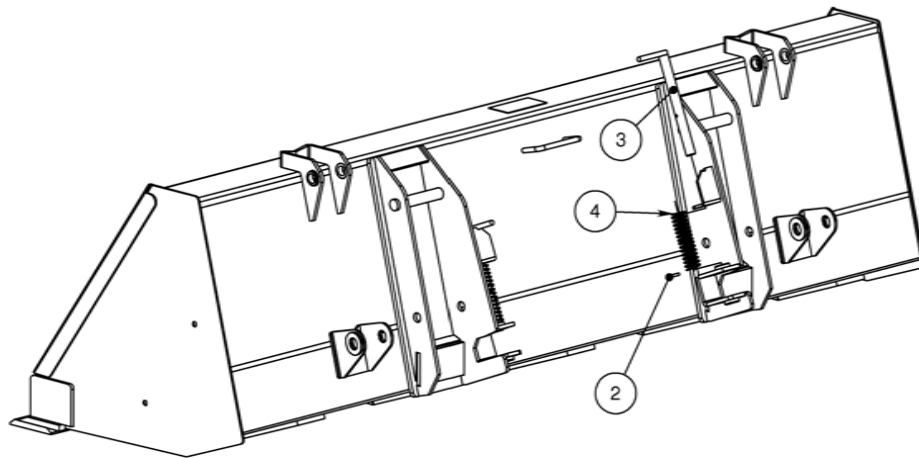

BUCKET PARTS SCHEDULE

7' JOHN DEERE 600 - 700 SERIES BUCKET

ITEM NO.	PART NUMBER	DESCRIPTION	QTY
	690000	7' JD BUCKET ASSEMBLY	
1	690005	7' JD BUCKET WELDMENT	1
2	650389	PIN-ROLL .25 X 1.5	2
3	690020	LATCH PIN	2
4	650388	SPRING .135 WIRE X 1.460ID X 4	4
BOLT-ON BLADE KIT (OPTIONAL)			
ITEM NO.	PART NUMBER	DESCRIPTION	QTY
	690052	7' BUCKET BOLT-ON BLADE KIT	
5	690055	7' BOLT ON BUCKET BLADE	1
6	673366	SCREW - .625-11 X 2.00 GR 5 PH	11
7	640159	WASHER - 5/8" SPRING LOCK	11
8	640142	NUT-.625-11 GR 5 HEX	11
CLEVIS & SLING LINK KIT (OPTIONAL)			
ITEM NO.	PART NUMBER	DESCRIPTION	QTY
9	689120	CLEVIS & SLING LINK KIT	1

HYDRAULIC SYSTEM INFORMATION

The hoses from the tractor valves are attached to the oil lines which are on the inside of the loader main frame.

Re-check all joints to prevent leakage after loader is mounted and in operation.

KEEP SYSTEM CLEAN - USE ONLY CLEAN OIL



CAUTION! It is of utmost importance that the hydraulic system of this loader be kept free from dirt and foreign matter.

All internal parts to the hydraulic system of your loader have been carefully cleaned, inspected, and plugged with protective caps before shipment. All protective caps should be kept in place until the hydraulic system is connected.

NOTE: Over 75 percent of all hydraulic failure and service is caused by dirt, etc. in the system.

REMEMBER - CLEAN OIL MEANS LONGER LIFE!

HYDRAULIC CYLINDERS INFORMATION

IMPORTANT: Read these service tips before beginning assembly of cylinder gland or piston.

1. Keep seals clean from the time they are removed from package until they are installed.
2. Clean the groove or bore into which the seal is to be fitted before installing the seal.
3. Never touch the seal lip in handling. Always pick up the seal by its outer member.
4. Inspect each seal lip carefully for nicks, scratches, and dirt at time of installation. If dirty use a soft, clean cloth and carefully wipe off seal. **DO NOT wipe seal with fingers, this only imbeds dirt in the seal.**



NEVER clean rubber related seals with a mineral based solvent! Clean rubber seals in denatured alcohol or non-mineral based solvents only.

NOTE: Seals can be made more pliable and easier to install, if first heated in hydraulic oil to 160°F. Never use direct heat on any seals.

HYDRAULIC CYLINDER PARTS DIAGRAM

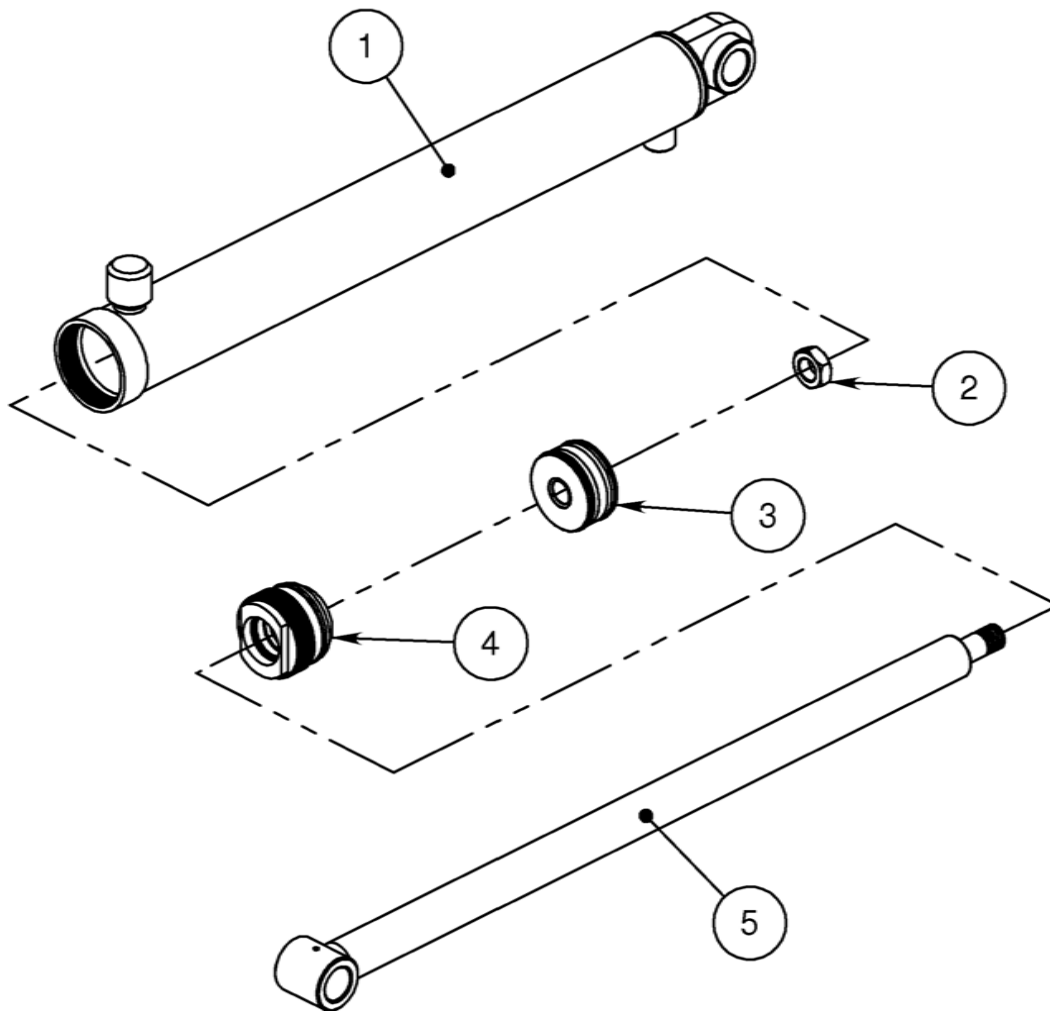

HYDRAULIC CYLINDER PARTS LIST

640 SL & NSL LIFT CYLINDER (Part No. 689927)

ITEM NO.	PART NO.	DESCRIPTION	QTY.
1	689927	Tube Weldment	1
2	661017	Locknut	1
3	675577	Piston Assembly	1
4	675570	Gland Assembly	1
5	689929	Rod Weldment	1

640 SL BUCKET CYLINDER (Part No. 690903)

ITEM NO.	PART NO.	DESCRIPTION	QTY.
1	690904	Tube Weldment	1
2	661017	Locknut	1
3	672904	Piston Assembly	1
4	672903	Gland Assembly	1
5	690906	Rod Weldment	1

640 NSL BUCKET CYLINDER (Part No. 689920)

ITEM NO.	PART NO.	DESCRIPTION	QTY.
1	689921	Tube Weldment	1
2	661017	Locknut	1
3	672904	Piston Assembly	1
4	672903	Gland Assembly	1
5	689924	Rod Weldment	1

3 1/4" CYLINDER SERVICE KITS WITH 1 3/4" SHAFT

KIT NO. 675574:

Complete kit with all seals needed to service one (1) 3 1/4" Cylinder. Consists of:

1 each	3 1/4" Gland "O" Ring
1 each	3 1/4" Backup Ring
1 each	1 3/4" U-cup Seal
1 each	1 3/4" Rod Wiper
2 each	3 1/4" U-cup Seal
1 each	1" Rod "O" Ring
1 each	1" Locknut

KIT NO. 675572:

Complete assembled 3 1/4" Cylinder Gland with all seals. Consists of:

1 each	3 1/4" Aluminum Gland
1 each	3 1/4" Gland "O" Ring
1 each	3 1/4" Backup Ring
1 each	1 3/4" U-cup Seal
1 each	1 3/4" Rod Wiper
1 each	1" Locknut

KIT NO. 675576:

Complete assembled 3 1/4" Cylinder Piston with all seals. Consists of:

1 each	3 1/4" Aluminum Piston
2 each	3 1/4" U-cup Seal
1 each	1" Rod "O" Ring
1 each	1" Locknut

KIT NO. 675573:

All seals needed to service one (1) 3 1/4" Cylinder Gland. Consists of:

1 each	3 1/4" Gland "O" Ring
1 each	3 1/4" Backup Ring
1 each	1 3/4" U-cup Seal
1 each	1 3/4" Rod Wiper
1 each	1" Locknut

KIT NO. 675575:

All seals needed to service one (1) 3 1/4" Cylinder Piston. Consists of:

2 each	3 1/4" U-cup Seal
1 each	1" Rod "O" Ring
1 each	1" Locknut

NOTE: Parts are only available in a kit form.

2 1/2" CYLINDER SERVICE KITS WITH 1 1/2" SHAFT

KIT NO. 662048:

Complete kit with all seals needed to service one (1) 2 1/2" Cylinder. Consists of:

1 each	2 1/2" Gland "O" Ring
1 each	2 1/2" Backup Ring
1 each	1 1/2" U-cup Seal
1 each	1 1/2" Rod Wiper
2 each	2 1/2" U-cup Seal
1 each	1" Rod "O" Ring
1 each	1" Locknut

KIT NO. 663317:

Complete assembled 2 1/2" Cylinder Gland with all seals. Consists of:

1 each	2 1/2" Aluminum Gland
1 each	2 1/2" Gland "O" Ring
1 each	2 1/2" Backup Ring
1 each	1 1/2" U-cup Seal
1 each	1 1/2" Rod Wiper
1 each	1" Locknut

KIT NO. 663318:

Complete assembled 2 1/2" Cylinder Piston with all seals. Consists of:

1 each	2 1/2" Aluminum Piston
2 each	2 1/2" U-cup Seal
1 each	1" Rod "O" Ring
1 each	1" Locknut

KIT NO. 662052:

All seals needed to service one (1) 2 1/2" Cylinder Gland. Consists of:

1 each	2 1/2" Gland "O" Ring
1 each	2 1/2" Backup Ring
1 each	1 1/2" U-cup Seal
1 each	1 1/2" Rod Wiper
1 each	1" Locknut

KIT NO. 662055:

All seals needed to service one (1) 2 1/2" Cylinder Piston. Consists of:

2 each	2 1/2" U-cup Seal
1 each	1" Rod "O" Ring
1 each	1" Locknut

NOTE: Parts are only available in a kit form.

CYLINDER GLAND SERVICE DIAGRAM

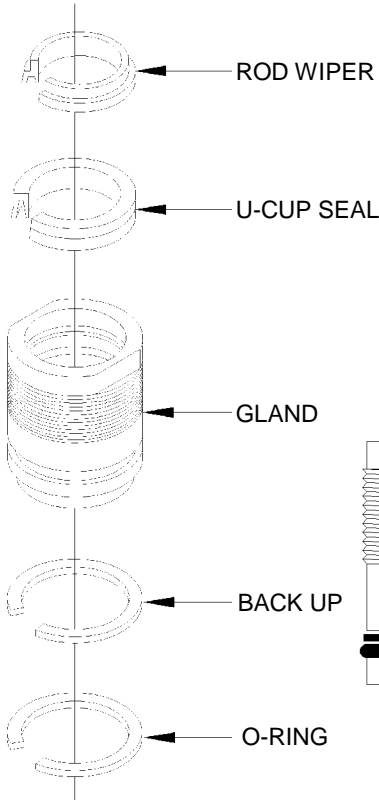

All gland seals shown with a section removed to facilitate correct installation.

Note: To install rod wiper and U-cup seal, fold similar to shape shown below, slip into gland bore and locate each in its respective groove. Tools are used to fold seals, take care not to damage sealing surfaces.

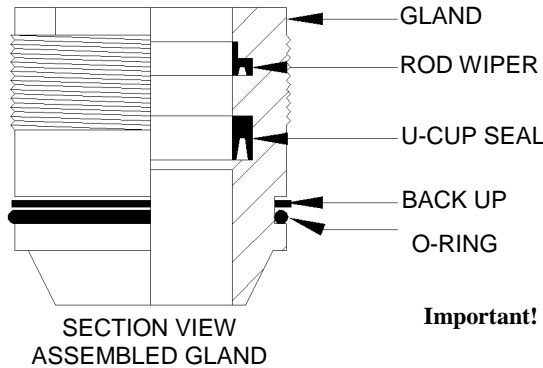

Important! Be sure all gland and piston seals have been installed correctly before cylinder is assembled!

CYLINDER PISTON SERVICE DIAGRAM

To Remove Seals:

Carefully cut across each seal with a sharp knife. Be sure not to scratch sealing surfaces of aluminum piston. If a sharp knife is not available. An electric soldering gun or hot iron may be used to melt throughout seals.

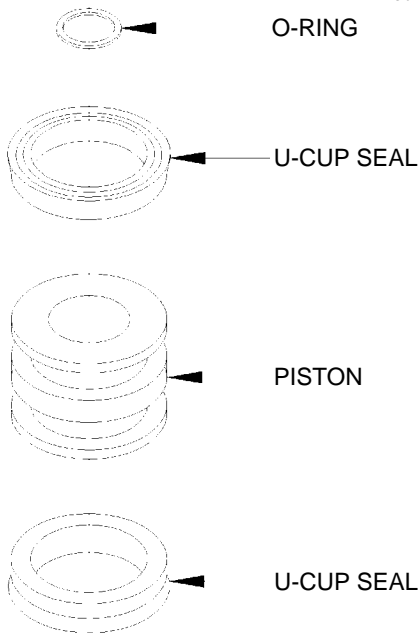

To Install Seals:

1. Thoroughly clean piston sealing surface of all foreign matter.
2. Heat new seals in hydraulic oil to 160° F. Never use a direct flame or heated water on hydraulic seals.
3. Remove seals from oil, wipe dry and install in piston grooves as shown in illustration at left. Be sure seals have completely seated in piston grooves before allowed to cool.
4. Replace piston on cylinder shaft and assemble cylinder when seals have cooled to room temperature.

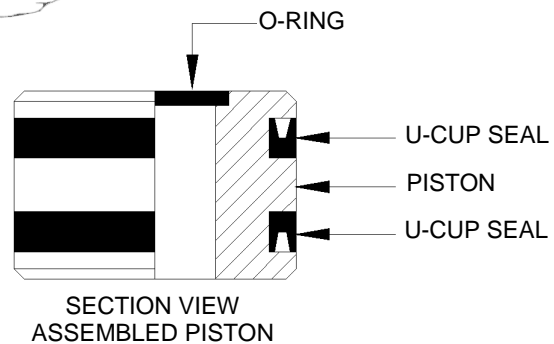



NEW LEGEND LOADER WARRANTY

LIMITED WARRANTY FOR NEW LEGEND EQUIPMENT COMPANY PRODUCTS

A. GENERAL PROVISIONS. "Legend" means Legend Equipment Company, 200 N. Cleveland, P.O. Box 409, Lennox, South Dakota 57039. The warranties described below are provided by Legend to the original purchasers of new products purchased from Legend or from an authorized Legend Dealer (the "Products"). Under these warranties, Legend will, at its option, repair or replace at its factory any Product covered under these warranties which is found to be defective in material and workmanship during the applicable warranty term or refund the purchase price paid for the defective Product. Customer will be responsible for labor charges for removing the defective Product and reinstalling the repaired or replacement Product, any premium charge for overtime labor requested of Legend and shipping charges to and from Legend's factory. These warranties are not transferrable.

B. WARRANTY PERIOD. Subject to exclusions and limitations set forth herein, each new Product is warranted for the number of years specified below. Each warranty term begins from the date of purchase regardless of delay in receipt of the Product by Customer due to the time required to process, handle, ship, assemble, construct and install the Product. Customer must retain proof of the date of purchase. Replacement parts for and repairs to the Product will be warranted only for the remainder of the original warranty term. The replacement parts for or repairs to the Product will not extend the warranty term beyond the original warranty term. Products include all parts, components and accessories.

PRODUCTS

Legend Loaders	Consumer Use	2 years
	Commercial or Government Use	1 year

C. ITEMS COVERED SEPARATELY. The Legend warranties do not cover any parts, components or materials that are part of the Product, or used in conjunction with the Product, that are not manufactured by Legend. Such parts, components and materials will be subject to the warranties provided by the manufacturer, if any.

D. WHAT IS NOT WARRANTED. Legend does not warrant and is not responsible for the following: (1) used Products; (2) modification or alteration of the Products; (3) Products that have not been properly installed or not installed in accordance with the instruction manual, improper assembly, or improper construction by any persons other than Legend employees; (4) depreciation, damage or loss caused by the use of parts, components or accessories not provided by Legend, unauthorized repairs, normal wear, lack of necessary and proper maintenance, a failure to follow operating instructions/recommendations, misuse, lack of proper protection during storage, vandalism or theft, exposure to the elements or corrosive materials, accidents or acts of nature including lightning, flooding, hail, straight winds and tornadoes; and (5) cosmetic damage or damage that does not hinder the functionality of the Products.

E. LIMITATIONS OF WARRANTIES AND CUSTOMER'S REMEDIES. To the extent permitted by law, neither Legend, the Dealer nor any person or company affiliated with either of them makes any warranties, representations, conditions or promises express or implied as to the quality, performance or freedom from defects of the Products covered by these warranties other than those set forth herein. THERE ARE NO IMPLIED WARRANTIES OF MERCHANTABILITY OR FITNESS FOR A PARTICULAR PURPOSE. NEITHER LEGEND, THE DEALER, NOR ANY PERSON OR COMPANY AFFILIATED WITH EITHER OF THEM WILL BE LIABLE FOR ANY DAMAGES, INCLUDING, BUT NOT LIMITED TO, INCIDENTAL, SPECIAL, EXEMPLARY, CONSEQUENTIAL, LOST PROFITS AND REVENUES, LOST USE OF THE PRODUCTS OR ANY OTHER PROPERTY, BODILY INJURY OR PROPERTY DAMAGE CLAIMS OF ANY PERSON, LOST COMMODITIES, REMOVAL OR STORAGE COSTS FOR THE PRODUCTS, OTHER EQUIPMENT AND COMMODITIES, DAMAGE TO THE ENVIRONMENT ARISING FROM OR IN ANY MANNER RELATED TO ANY RELEASE OF HAZARDOUS MATERIALS, AND REMEDIATION EXPENSES THEREFORE, WHETHER BASED ON CONTRACT, TORT, STRICT LIABILITY OR ANY OTHER LEGAL BASIS, EVEN IF ADVISED OF THE POSSIBILITY OF SUCH DAMAGES. IN NO INSTANCE WILL LEGEND, THE DEALER OR ANY PERSON OR COMPANY AFFILIATED WITH EITHER OF THEM BE LIABLE TO CUSTOMER OR ANY PERSON IN AN AMOUNT IN EXCESS OF THE PURCHASE PRICE PAID BY CUSTOMER FOR THE PRODUCT.

F. NO DEALER WARRANTY. THE DEALER HAS NO AUTHORITY TO MAKE ANY WARRANTY, REPRESENTATION, CONDITION OR PROMISE ON BEHALF OF LEGEND, OR TO MODIFY THE TERMS OR LIMITATIONS OF THIS WARRANTY IN ANY WAY.

G. GOVERNING LAW/VENUE. These warranties, and all terms set forth herein, are governed by the laws of the State of South Dakota and, where applicable, the laws of the United States of America. Any and all disputes arising from these warranties, the purchase and use of the Products, bodily injury and property damage claims or otherwise must be venued in the South Dakota Circuit Court sitting in Minnehaha County, South Dakota. Customer agrees to such venue and waives any challenge to such court's jurisdiction based upon lack of personal jurisdiction or inconvenience.

H. SECURING WARRANTY SERVICE. In order to receive warranty services, customer must give Legend written notice of a warranty claim within 30 days of the date of discovery of the defective materials or workmanship, and Customer must complete the following steps:

(1)	Obtain from Legend a Return Materials Authorization Number ("RMA Number") by calling the Customer Service Department at (855) 534-3784 or e-mail Legend at info@Legendequip.com , and providing the following information:
	An explanation as to why the Product is being returned.
	The name of the territory representative, Dealer or Legend salesperson from whom the Product was purchased.
	The Dealer's identification number.
	The invoice number and date of purchase.
	Customer's name, phone number, fax number, mailing address and email address.
	The date that the Product will be returned.
(2)	Pay the shipping charges to ship the Product to Legend's factory, and the return shipping charges.
(3)	Ship the Product to Legend at 200 N. Cleveland, Lennox, South Dakota 57039.

TORQUE SPECIFICATIONS

1. Tightening Bolts & Nuts

Check all loader bolts and nuts for tightness every 50 working hours. The movement of the loader over rough terrain may cause bolts to come under pressure and over a long period of time some slight stretching of the bolt may occur. The slack created may need to be taken up by tightening. Please refer below for recommended torque settings.

Metric Recommended Torque Settings

Size	Class 8.8				Class 10.9			
	Lubricated		Dry		Lubricated		Dry	
	N*m	Lb-ft	N*m	Lb-ft	N*m	Lb-ft	N*m	Lb-ft
M6.....	9	6.5	11	8.5.....	13	9.5	17	12
M8.....	22	16	28	20.....	32	24	40	30
M10.....	43	32	55	40.....	63	47	80	60
M12.....	75	55	95	70.....	110	80	140	105
M14.....	120	88	150	110.....	175	130	225	165
M16.....	190	140	240	175.....	275	200	350	225
M18.....	260	195	330	250.....	375	275	475	350
M20.....	375	275	475	350.....	530	400	675	500
M22.....	510	375	650	475.....	725	540	925	675
M24.....	650	475	825	600.....	925	675	1150	850
M27.....	950	700	1200	875.....	1350	1000	1700	1250
M30.....	1300	950	1650	1200.....	1850	1350	2300	1700
M33.....	1750	1300	2200	1650.....	2500	1850	3150	2350
M36.....	2250	1650	2850	2100.....	3200	2350	4050	3000

SAE Recommended Torque Settings

Size	Grade 5				Grade 8			
	Lubricated		Dry		Lubricated		Dry	
	N*m	Lb-ft	N*m	Lb-ft	N*m	Lb-ft	N*m	Lb-ft
1/4.....	9.5	7	12	9.....	13.5	10	17	12.5
5/16.....	20	15	25	18.....	28	21	35	26
3/8.....	35	26	44	33.....	50	36	63	46
7/16.....	55	41	70	52.....	80	58	100	75
1/2.....	85	63	110	80.....	120	90	150	115
9/16.....	125	90	155	115.....	175	130	225	160
5/8.....	170	125	215	160.....	215	160	300	225
3/4.....	300	225	375	280.....	425	310	550	400
7/8.....	490	360	625	450.....	700	500	875	650
1.....	725	540	925	675.....	1050	750	1300	975
1-1/8.....	900	675	1150	1200.....	2050	1500	2600	1950
1-3/8.....	1700	1250	2150	1550.....	2700	2000	3400	2550
1-1/2.....	2250	1650	2850	2100.....	3600	2650	4550	3350



DO NOT use these values if a different torque value or tightening procedure is given for a specific application. Torque values listed are for general use only and include a +/- 10% variance. Check tightness of fasteners periodically. DO NOT use air powered wrenches. Shear bolts are designed to fail under predetermined loads. Always replace shear bolts with identical grade.



640 SPECIFICATIONS

640 Self-Leveling Specifications:

- Maximum lift height: **146"**
- Digging depth: **7"**
- Roll-back angle at ground level: **38 degrees**
- Dump angle at maximum height: **80 degrees**
- Lift & breakout capacity: **Rated at 17.5 gpm/2500 psi**
- Breakout force at pivot pin: **5,890 lbs.**
- Lift capacity to full height at pivot pin: **3,410 lbs.**

640 Non Self-Leveling Specifications:

- Maximum lift height: **146"**
- Digging depth: **7"**
- Roll-back angle at ground level: **15 degrees**
- Dump angle at maximum height: **39 degrees**
- Lift & breakout capacity: **Rated at 17.5 gpm/2500 psi**
- Breakout force at pivot pin: **5,800 lbs.**
- Lift capacity to full height at pivot pin: **3,300 lbs.**

The 640 Is The Front-End Loader Solution To Fit The Following JD Series Tractors:

6000 Series:

6110, 6120, 6130, 6200, 6210, 6215, 6220, 6230, 6300, 6310, 6320, 6330, 6400, 6405, 6410, 6415, 6420, 6430

Utility Series:

2350, 2355, 2550, 2555, 2750, 2755

